



三友繼電器
SANYOU RELAYS

三友联众集团股份有限公司
Sanyou Corporation Limited

敬业 诚信
团结 创新

电话 Tel: (86)-769-82618888

传真 Fax: (86)-769-85914553

网址 Web site: www.sanyourelay.com

产品规格确认书

Specification for approval

文件编号 File No:

顾客 Customer: PANEL

顾客产品名称 Custorm Product Name: Line Filter

顾客零件号 Custorm Part No: _____

三友产品名称 SY Product Name: SY-0.7A-10mH CMC

三友产品型号 SY Product model: SY14TF-0070-1000-001

发布日期 Publish Date: 2023.2.12

版本 Version: V1.0

特别说明: 此确认书请顾客在 2 周内确认, 如未在规定时间内答复, 则视为同意。

三友审批签字 Signature by Sanyou			顾客签字或盖章 stamp of signature by customer
编制 Make	审核 Check	批准 Approved	

Especially claim: This specification should be checked in 2 weeks, if had not answered in the scheduled time ,then regards as the agreement.

变更版记录 Revisions

版本 Version No.	变更内容 Change description	变更原因 Reason	日期 Date	修改 Drafted by	审核 Checked by
V1.0	初版	/	2023. 2. 12	邹一鸣	黄玉华

目录 Catalog

1. 外形尺寸(Outline Dimensions)
2. 推荐 PCB 安装尺寸 (Suggested PCB Layout)
3. 原理图 (Schematic Diagram)
4. 绕线参数 (Winding Parameter)
5. 电气特性(Electrical Characteristics)
6. 材料表 (Material List)
7. 产品工艺要求(Technological Requirements)
8. 推荐焊接条件 (Recommend Soldering Conditions)
9. 可靠性测试条件 (Reliability Testing Conditions)

产品规格确认书 Specification for approval

1, 外形尺寸(Outer dimensions) (单位: mm)

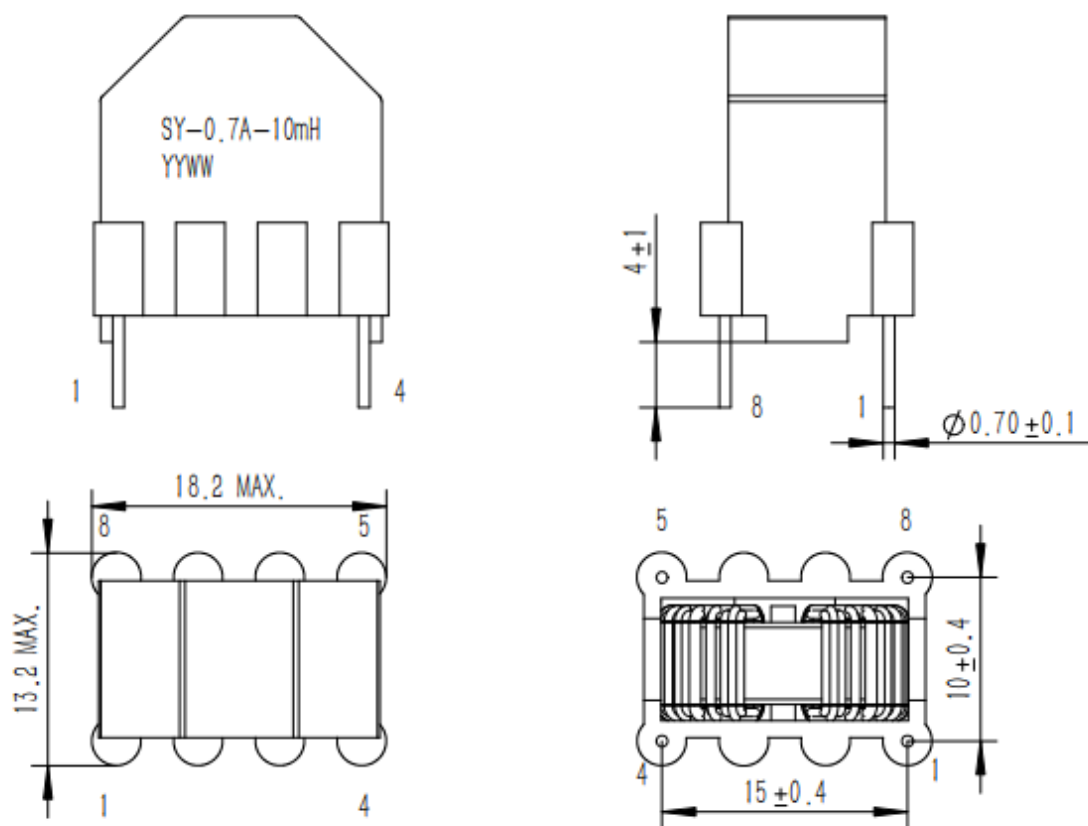

2, 推荐 PCB 安装尺寸 (Suggested PCB layout) (单位: mm)

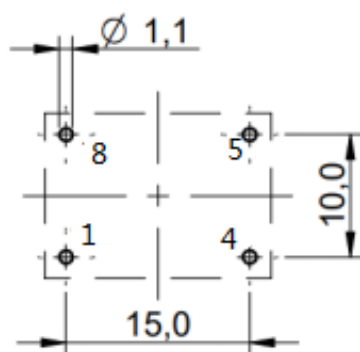

3, 原理图 (Schematic diagram)

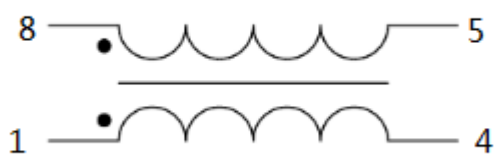

产品规格确认书 Specification for approval

4, 绕线参数 (Winding parameter)

起线-尾线 Start-finished pin	线径规格 Wire diameter	圈数 Turns	绕线方式 Winding condition	胶带圈数 Turns of tape
1-4	2UEW F 0.4mm	42(REF)	close	\
8-5	2UEW F 0.4mm	42(REF)	close	\

备注: 绕线圈数参考, 以电感量为准。The turns of coil specified below is only for reference, the actual number is decided by the inductance

5, 产品工艺要求 (Technological requirements):

- 1) 绕线平整, 两个绕组圈数相同。The turns of two coils must be same, and the winding shall be flat without overlap.
- 2) 磁芯, 隔板和底座点胶固定。Fasten core and bobbin with glue.
- 3) 如客户无要求, 产品标签为 SY-0.7A-10mH 否则按照客户要求 if no rerequirements, marked the inductor with: SY-1A-6.8mH, else meets customer's specification.

6, 电气特性 (Electrical characteristics)

项目 Item	测试引脚 Pin NO.	规格 SPEC.	测试条件 Conditions
电感 Inductance	1-4	10mH ± 30%	10KHz 100mV 20°C (LCR 测试仪器内阻 100 Ω)
	8-5	10mH ± 30%	
电感偏差 Inductance deviation	1-4 - 8-5	300uH max	10KHz 100mV 20°C (LCR 测试仪器内阻 100 Ω)
漏感 Leakage inductance	1-4	300uH max	10KHz 100mV 20°C (LCR 测试仪器内阻 100 Ω) PIN8-5short
直流电阻 DC resistance	1-4	0.55 Ω max	20°C
	8-5	0.55 Ω max	
高压测试 Hi-pot test	(1-4)-(2-3)	1.5KV	2S 1mA
额定电压 Rated Voltage		250V MAX.	50Hz/60Hz
绝缘电阻 Insulation resistance	(1-4)-(2-3)	100M Ω min	500VDC
工作温度范围 Operation Temperature		-40~125°C	包含线圈发热导致的温度升高 (including coil's temperature rising)

产品规格确认书 Specification for approval

7, 材料表 (Material list)

编号 NO.	类别 Description	材料 Material	供应商 MANUFACTURER	UL NO.	温度等级 TEMP.
1	Core	T14 GH10	NANTONG GUANYOUDA MAGNETIC INDUSTRY CO. LTD	/	130°C
			SHANDONG KAITONG ELECTRON CO., LTD	/	125°C
2	Case	PM-9823 (black)	SUMITOMO BAKELITE CO LTD	E41429	150°C
		T375HF (black)	CHANGCHU PLASTICS CO., LTD	E59481	150°C
3	Wire	2UEW F	Guangdong Jinyan Electrotechnics or equivalent	E238500	155°C
4	Epoxy	A/B (black)	Santong or equivalent	/	130°C
5	Solder	Sncu	Qiandao or equivalent	/	/

8, 推荐焊接条件 (Recommend soldering conditions)

- 1) 焊接方式: 波峰焊 (wave soldering)
- 2) 典型焊接曲线 (Classification wave soldering profile)

Classification Wave Soldering Profile:

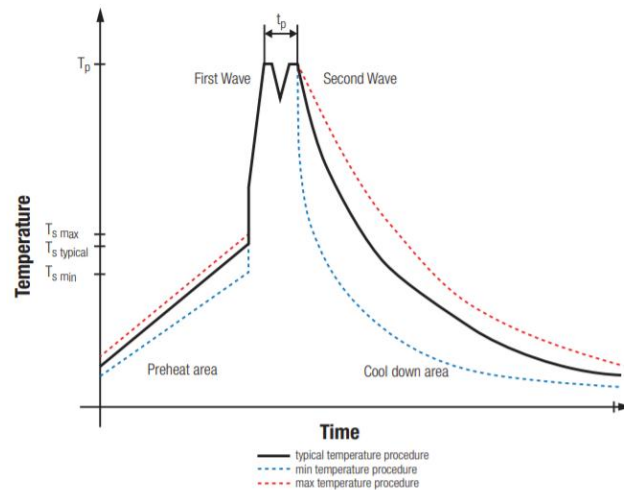

产品规格确认书 Specification for approval

Classification Wave Soldering Profile:

Profile Feature		Pb-Free Assembly
Preheat Temperature Min	$T_{s \text{ min}}$	100 °C
Preheat Temperature Typical	$T_{s \text{ typical}}$	120 °C
Preheat Temperature Max	$T_{s \text{ max}}$	130 °C
Preheat Time t_s from $T_{s \text{ min}}$ to $T_{s \text{ max}}$	t_s	70 seconds
Ramp-up Rate	ΔT	150 °C max.
Peak Temperature	T_p	250 °C - 260 °C
Time of actual peak temperature	t_p	max. 10 seconds max. 5 seconds each wave
Ramp-down Rate, Min		~ 2 K/ second
Ramp-down Rate, Typical		~ 3.5 K/ second
Ramp-down Rate, Max		~ 5 K/ second
Time 25 °C to 25 °C		4 minutes

refer to EN61760-1:2006

9. 可靠性测试条件 (Reliability Testing Conditions)

序号 (NO.)	测试项目 (Item)	试验条件 (Conditions)	判定标准 (Criterion)
1	高温存储 High temperature storage	125°C 300 小时 125°C 300Hours	室温放置 2h 后, 各项性能满足规格书要求 After 2 hours at room temperature, the performance meets the requirements of the specifications
2	低温存储 Low temperature storage	-40°C 300 小时 -40°C 300Hours	室温放置 2h 后, 各项性能满足规格书要求 After 2 hours at room temperature, the performance meets the requirements of the specifications
3	冷热冲击 Thermal shock	-40°C 30 分钟 ~ 125°C 30 分钟 10 个循环 -40°C 30 minutes ~ 125°C 30minutes 10 cycles	室温放置 2h 后, 各项性能满足规格书要求 After 2 hours at room temperature, the performance meets the requirements of the specifications
4	湿热试验 Damp heat test	温度 40°C, 湿度 93%RH 240 小时 Temperature 40°C humidity 93%RH 240 hours	室温放置 2h 后, 各项性能满足规格书要求 After 2 hours at room temperature, the performance meets the requirements of the specifications
5	电寿命试验 Life test	额定电流 0.6A 1000 小时 Rated current 1A 1000Hours	试验完成后, 各项性能满足规格书要求 After the test, the performance meets the requirements of the specifications